

It is the user's responsibility to ensure the required connection requirements

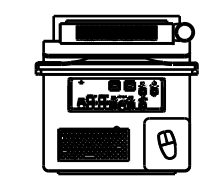
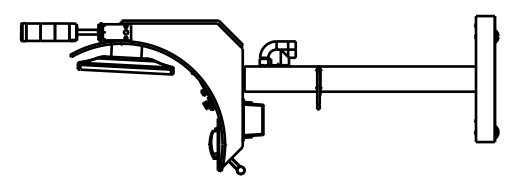
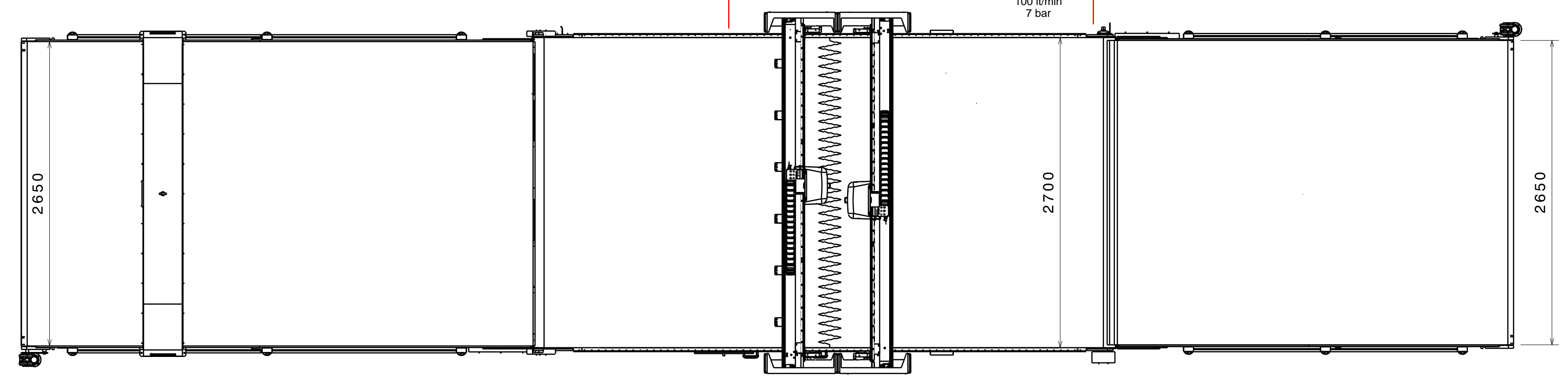
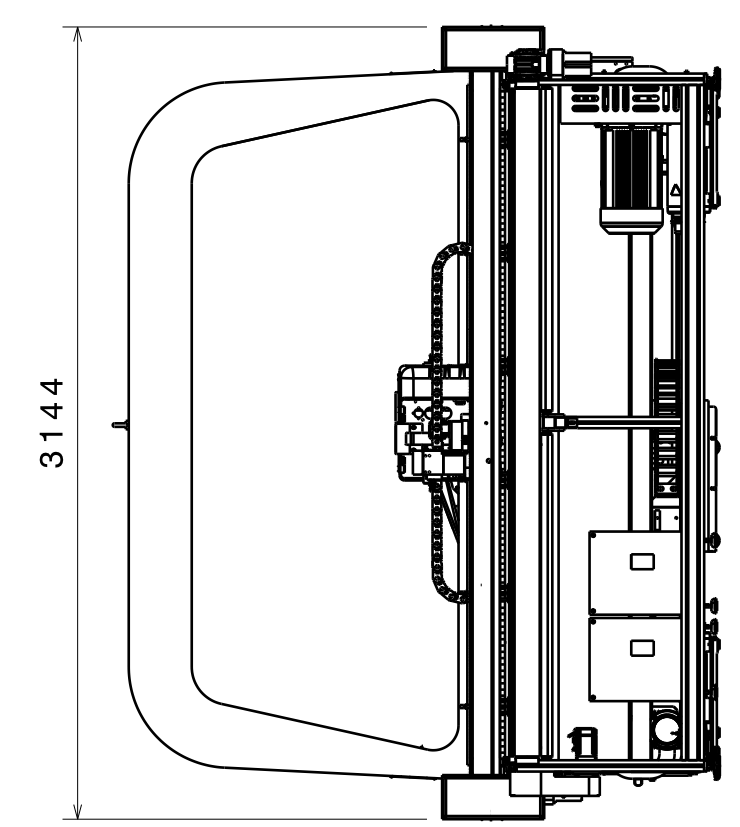
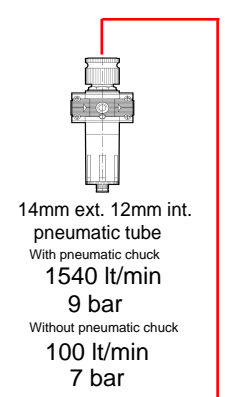
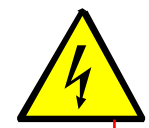
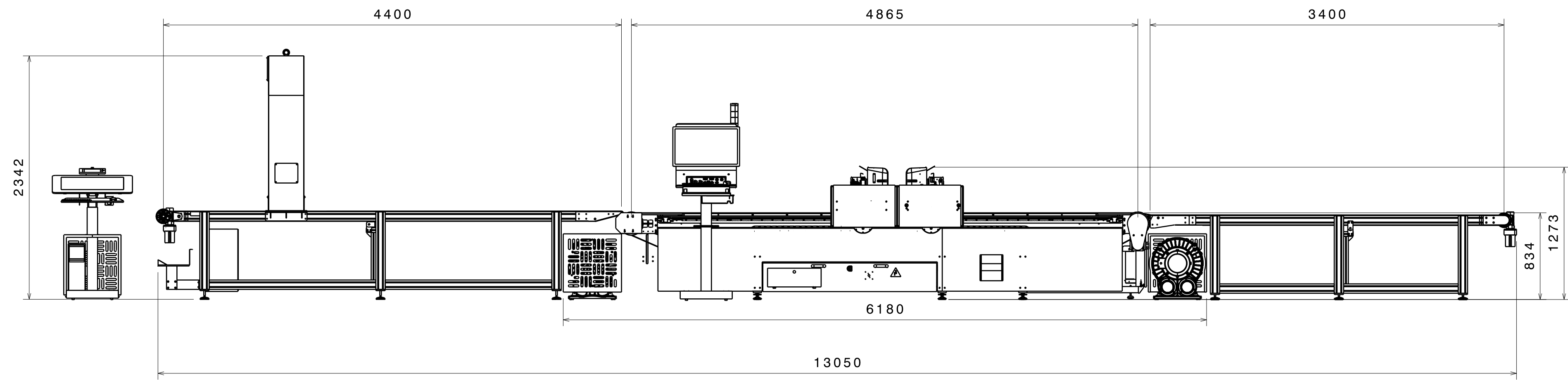

|                   |                      |
|-------------------|----------------------|
| MODEL             | <b>FXC 2H 3026 B</b> |
| WEIGHT            | 4050 Kg              |
| RATED VOLTAGE     | 480 V                |
| PHASES            | 3 + N                |
| NOMINAL FREQUENCY | 50/60 Hz             |
| NOMINAL CURRENT   | 45 A                 |
| NOMINAL POWER     | 26 kW                |

Thermal switcher required: 0.3 A in "D" curve